

The first name in Italian sofas

the modern collection

01
2013

alberta®



The first name in Italian sofas



the modern collection

01

La **modern collection** accoglie ed esprime le più concrete ed attuali istanze del vivere lo spazio abitativo. Al di là della qualità che è un valore assoluto e dato per scontato, le parole chiave di questa collezione sono: design dalle linee pure, innovativo ed originale, personalizzazione attraverso una vera libertà di scelta ed interpretazione, garanzia di piacevolezza sensoriale e di comfort. Apriamo così il nostro ventaglio di soluzioni. Ed ognuno ci vedrà il proprio mondo.

The **modern collection** embraces and expresses the most genuine, topical aspirations in modern interior décor. Along with quality, which is an absolute, foregone value, the key features of this collection are: innovative, original designs with clean lines; customisation assured by real freedom of choice and interpretation; guaranteed visual and physical comfort and pleasure. We open our treasure chest of solutions. Everyone will find their own world inside it.

La **modern collection** accueille et exprime les exigences les plus concrètes et actuelles de la manière de vivre la maison aujourd'hui. Au-delà de la qualité qui est une valeur absolue et qui va de soi, les mots clé de cette collection sont : design aux lignes pures, innovation et originalité, personnalisation à travers une vraie liberté de choix et d'interprétation, garantie de plaisir sensoriel et de confort. Ouvrons donc notre éventail de solutions. Et chacun y verra son propre monde.

Modern collection ist eine Sammlung und ein Ausdruck für die konkreten und überaus aktuellen Ansprüche, die an modernen Wohnkomfort gestellt werden. Abgesehen von Qualität, die einen absoluten Wert darstellt und als selbstverständlich vorausgesetzt wird, sind die wesentlichen Merkmale dieser Kollektion: Design mit klaren, innovativen und originellen Linien, individuelle Gestaltung durch vielfältige Auswahl und Möglichkeiten der Interpretation, angenehme sinnliche Empfindungen und Komfort. So öffnen wir das breite Spektrum unserer Lösungen. Eine eigene Welt für jeden.

alberta®

MANHATTAN	06
BROADWAY	26
RALPH	38
BLOW	50
OVERLAND	70
WILD	78
SUMMER	94
KALINDA	112

disegni tecnici / <i>technical drawings</i>	118
descrizioni tecniche / <i>technical descriptions</i>	136
COMPANY PROFILE	140



MANHATTAN

big city living



MANHATTAN



MANHATTAN



PCENJMNT - Tessuto | fabric | tissu | Stoff:
528P Mirto Grigioperla, cat. 5



1MNTJ21 - Tessuto | fabric | tissu | Stoff:
528P Mirto Grigioperla, cat. 5



1MNTJ21 - Tessuto | fabric | tissu | Stoff:
528P Mirto Grigioperla, cat. 5

MANHATTAN



MANHATTAN



MANHATTAN



MANHATTAN



MANHATTAN



MANHATTAN



alberla

Liberamente

Free

Mai identico a se stesso, lo spazio abitativo si trasforma liberamente in sintonia con i cambiamenti nel tempo. Solo linee essenziali e pulite consentono questo divenire.

*Never the same, your living space evolves constantly and freely with the times.
Only clean, essential lines allow this freedom.*



BROADWAY

living in the spotlight







BROADWAY



BROADWAY



alberta

Idealmente

Ideal

Il nuovo ideale? Il comfort. Un valore ed un assoluto. Linee, forme e materiali concorrono a creare questa sensazione per tutti irrinunciabile. Ormai sinonimo di casa.

The new ideal? Comfort. An absolute value. Lines, shapes and materials come together to deliver this essential ideal. Comfort means home.



RALPH



RALPH





RALPH



alberta.

Sensorialmente

Sensational

La qualità di materiali si traduce in sensazioni:
il calore dei tessuti, la morbidezza straordinaria
della pelle, la bellezza delle finiture.

*Quality materials produce genuine sensations:
the warmth of the fabrics, the extraordinary
softness of the leather, the beauty of the finishes.*



BLOW

a breath of fresh air



BLOW



BLOW



2BLWD3MB



BLOW



BLOW



BLOW



BLOW







BLOW

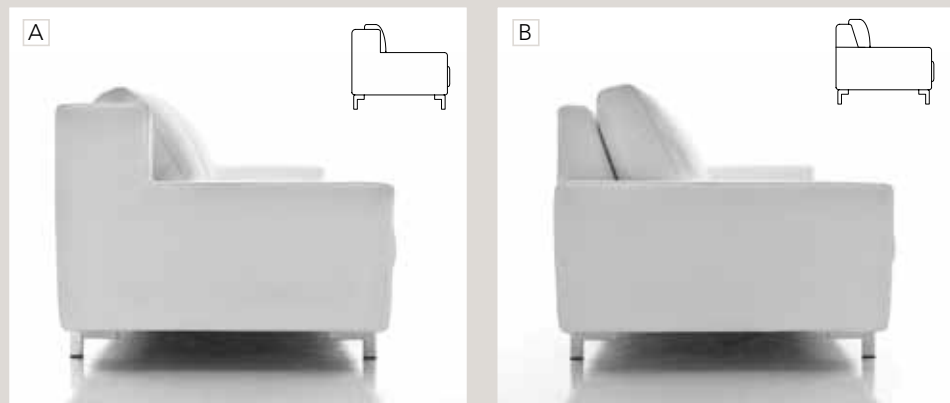



Positivamente

Positiv

Una visione positiva e serena del proprio spazio personale è il risultato di scelte pure e vere. Nulla deve creare contrasto ma solo armonia ed eleganza fluida.

A positive, serene vision of your space, the result of pure, sincere choices. Nothing is out of place, everything is in perfect harmony and infused with a fluid elegance.

OVERLAND

exploring new comfort



OVERLAND



OVERLAND



alberta.

Manualmente

Manual

Antiche professioni e lavorazioni artigianali eredi delle tradizioni di bottega. Attenzione alla qualità della materia prima e cura maniacale dei dettagli.

Ancient methods worked by hand and crafts from the tradition of the workshop. The utmost care in selecting raw materials, painstaking attention to each and every detail.



WILD

the relaxed side of life



WILD



WILD



WILD



WILD



WILD



2WILPM - Pelle | leather | cuir | Leder:
954 Fjord, cat. G



2WILP - Pelle | leather | cuir | Leder:
954 Fjord, cat. G



2WILPS - Pelle | leather | cuir | Leder:
946 Fjord, cat. G

WILD



alberta

Ecletticamente

Eclectic

Collezioni aperte ad ogni suggestione grazie ad un equilibrio eletto. Linee minimal. Sobrietà di colore ed attualità di ispirazione.

Incredibly balanced collections to satisfy any desire. Minimal lines, sober colours and contemporary inspiration.

SUMMER

comfort for all seasons



SUMMER



SUMMER



SUMMER





SUMMER



SUMMER



OSMRC6 - Pelle | leather | cuir | Leder.
954 Fjord, cat. G

PROFONDO | DEEP | PROFOND | TIEF | 107
2SMRD3MPR - Pelle | leather | cuir | Leder: 954 Fjord, cat. G

SUMMER



alberla

Virtuosamente

Virtuous

Virtù percepibili alla vista ed al tatto.
Creatività originale nel pensiero e nelle forme
tradotte in innovative soluzioni di design.

*Virtues as clear to the eye as they are to the
touch. Inspired creativity and shapes that
become innovative design solutions.*



KALINDA

elegant wellness





KALINDA





disegni tecnici
technical drawings

alberla

MANHATTAN

Tessuto | fabric | tissu | Stoff



COMPOSIZIONI / COMPOSITIONS / COMPOSITIONS / KOMPOSITIONEN

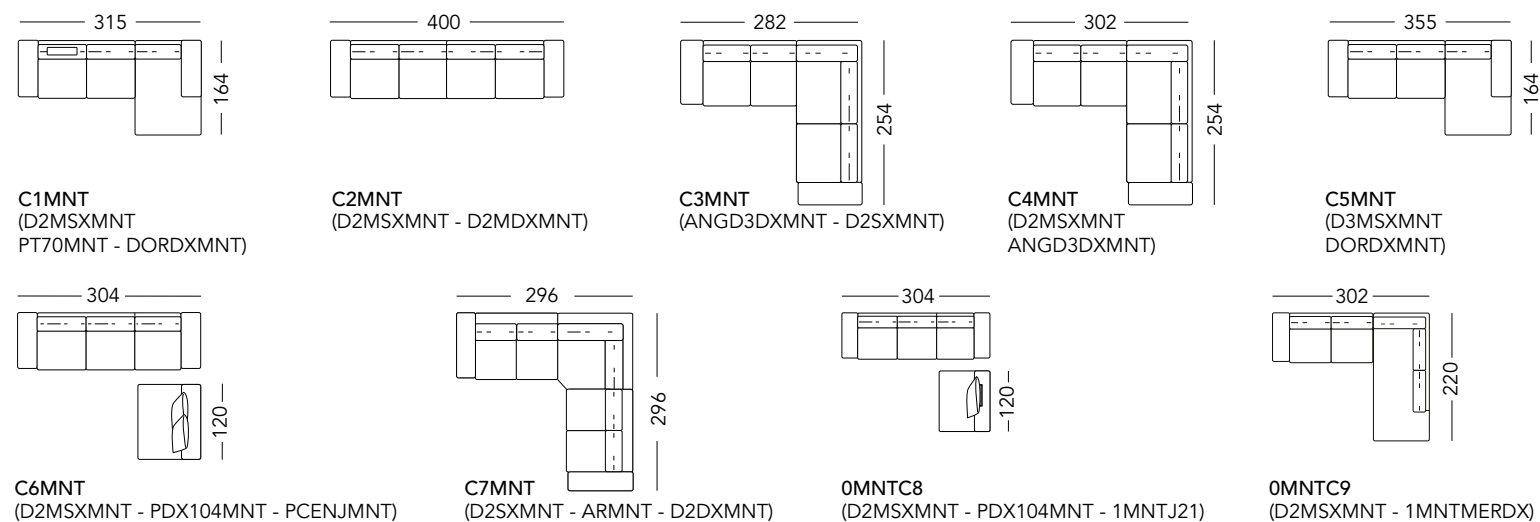

ELEMENTI / ELEMENTS / ELEMENTS / ELEMENTE

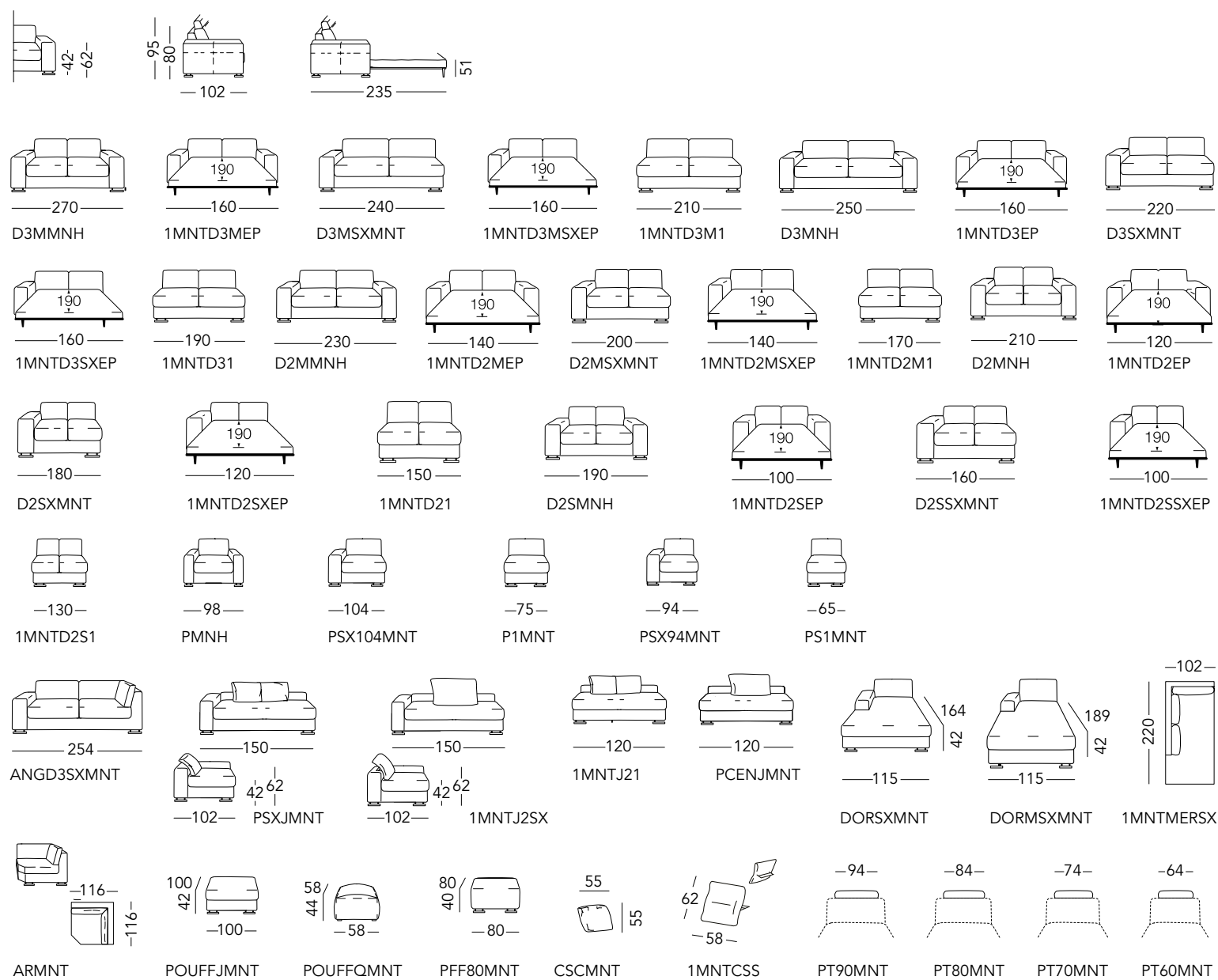

MANHATTAN

Pelle | leather | cuir | Leder



COMPOSIZIONI / COMPOSITIONS / COMPOSITIONS / KOMPOSITIONEN

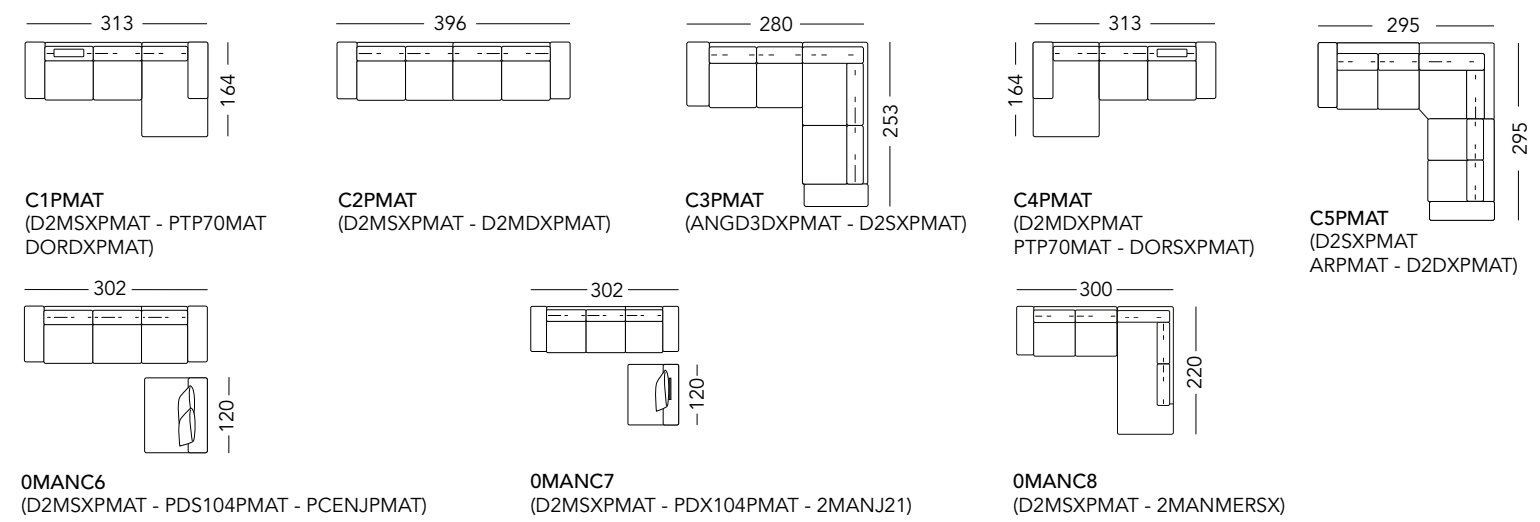

ELEMENTI / ELEMENTS / ELEMENTS / ELEMENTE

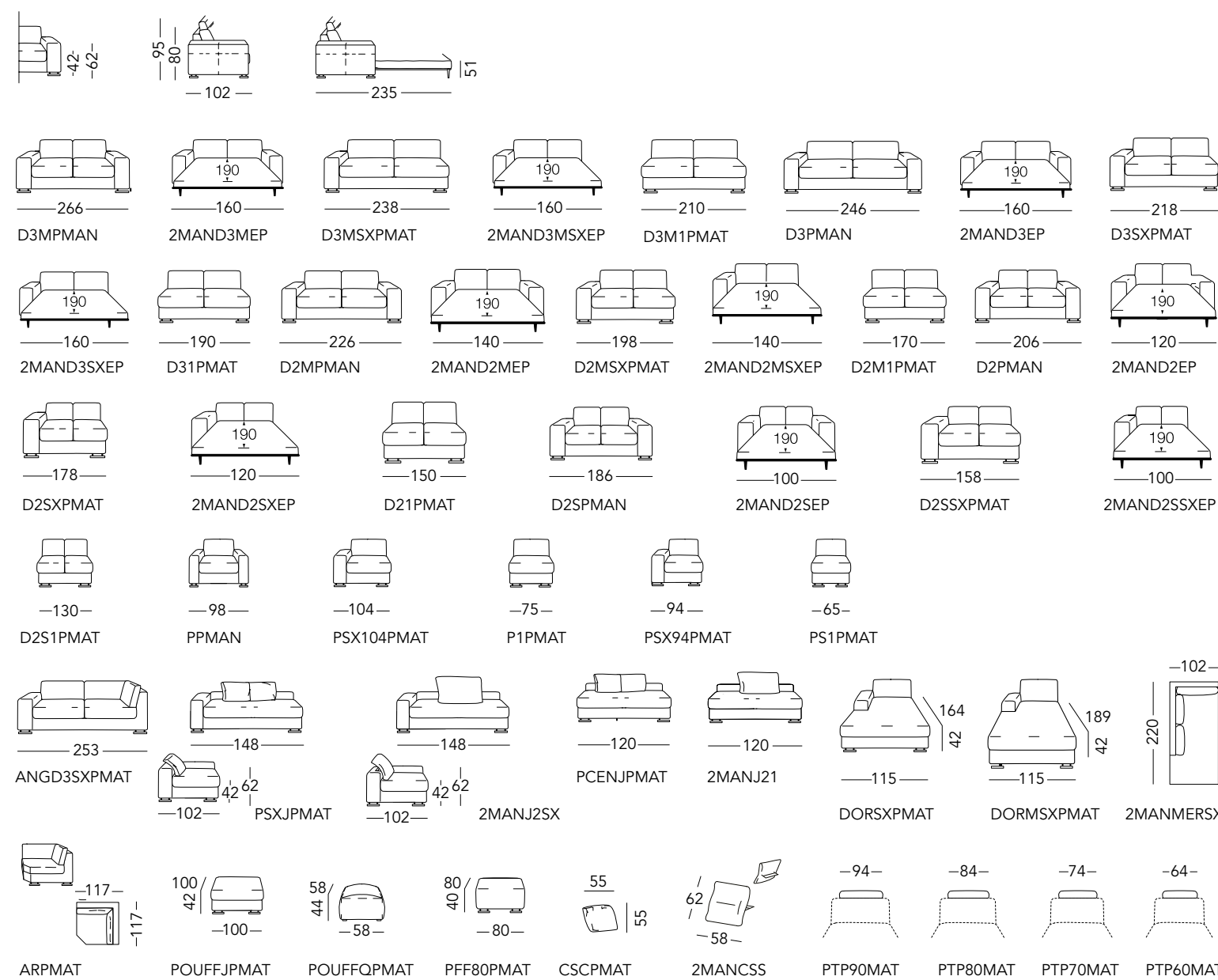

BROADWAY
Tessuto | fabric | tissu | Stoff



COMPOSIZIONI / COMPOSITIONS / COMPOSITIONS / KOMPOSITIONEN

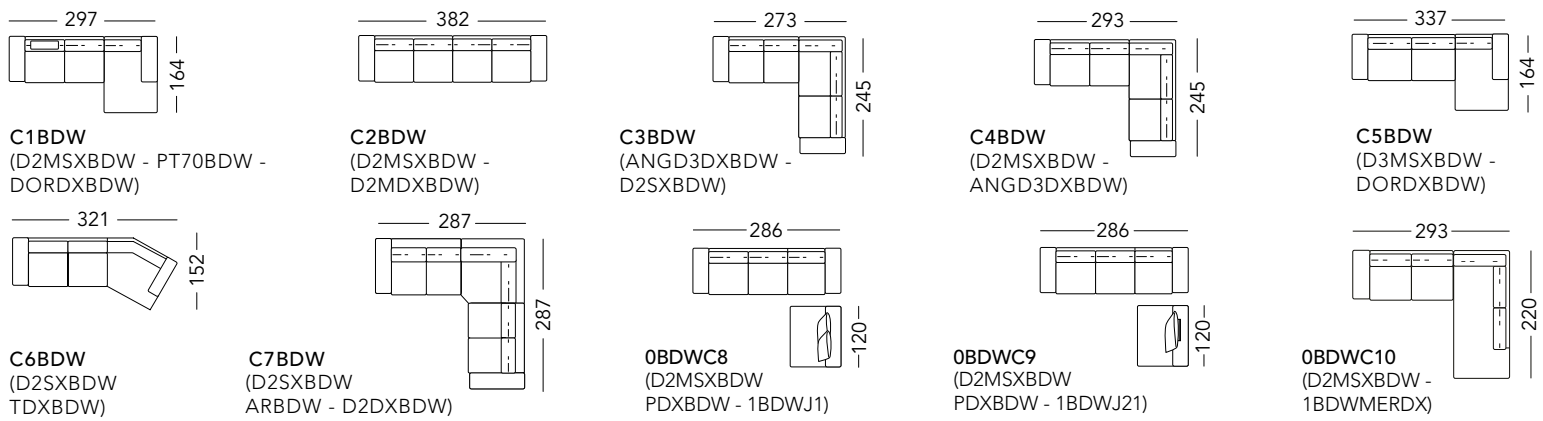

ELEMENTI / ELEMENTS / ELEMENTS / ELEMENTE

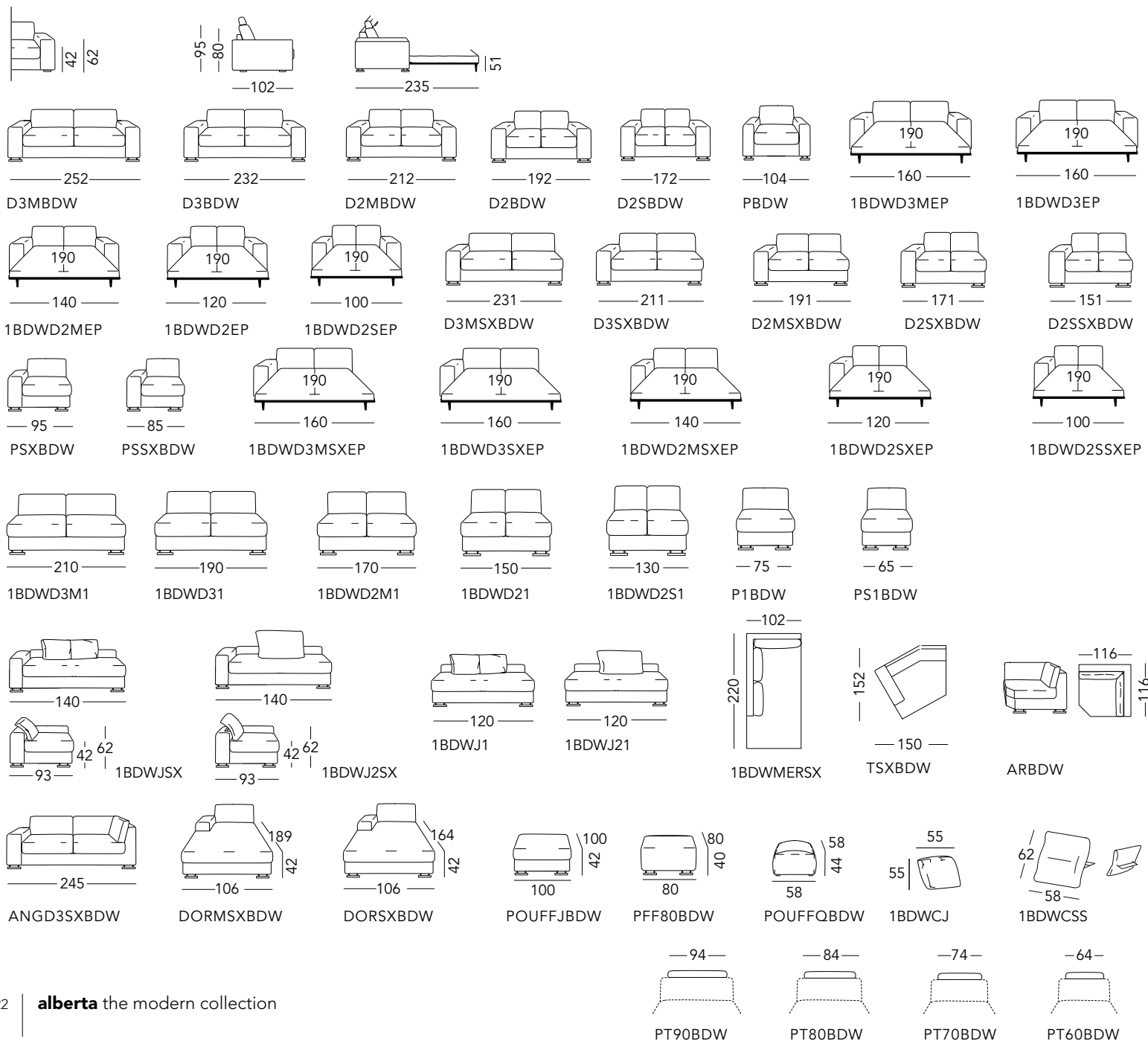

BROADWAY
Pelle | leather | cuir | Leder



COMPOSIZIONI / COMPOSITIONS / COMPOSITIONS / KOMPOSITIONEN

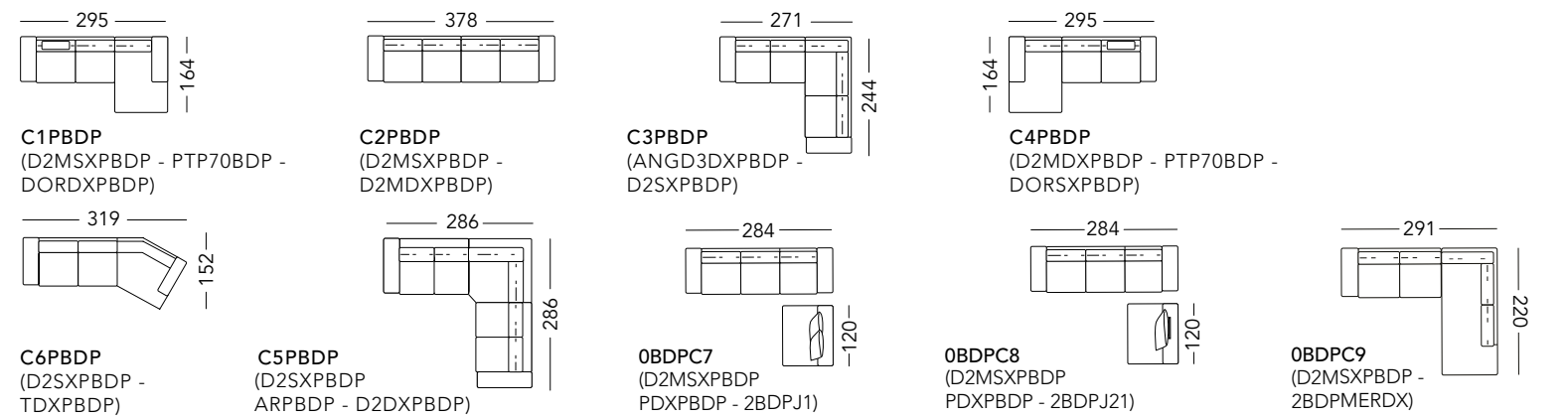

ELEMENTI / ELEMENTS / ELEMENTS / ELEMENTE

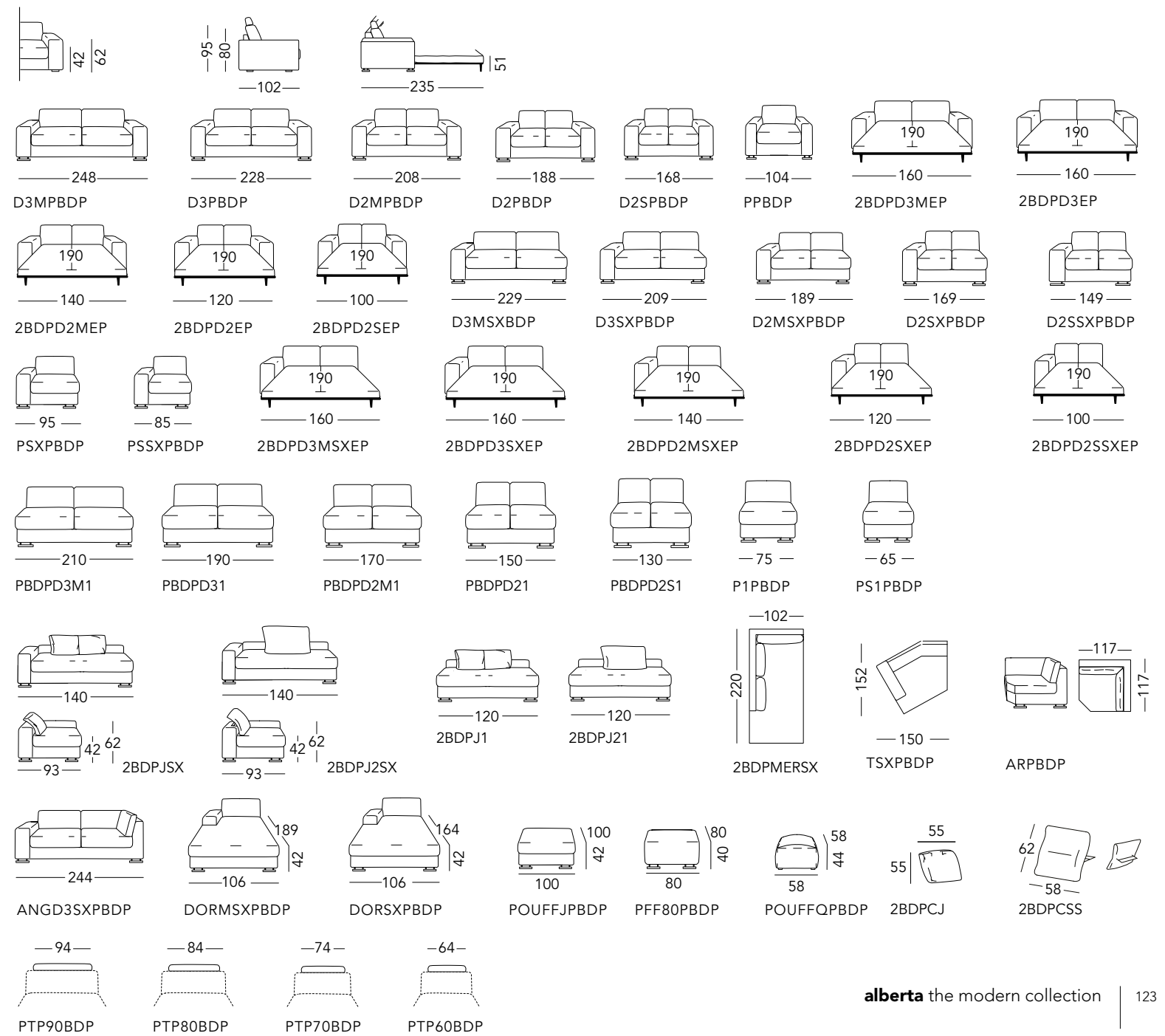

RALPH

Tessuto | fabric | tissu | Stoff



COMPOSIZIONI / COMPOSITIONS / COMPOSITIONS / KOMPOSITIONEN

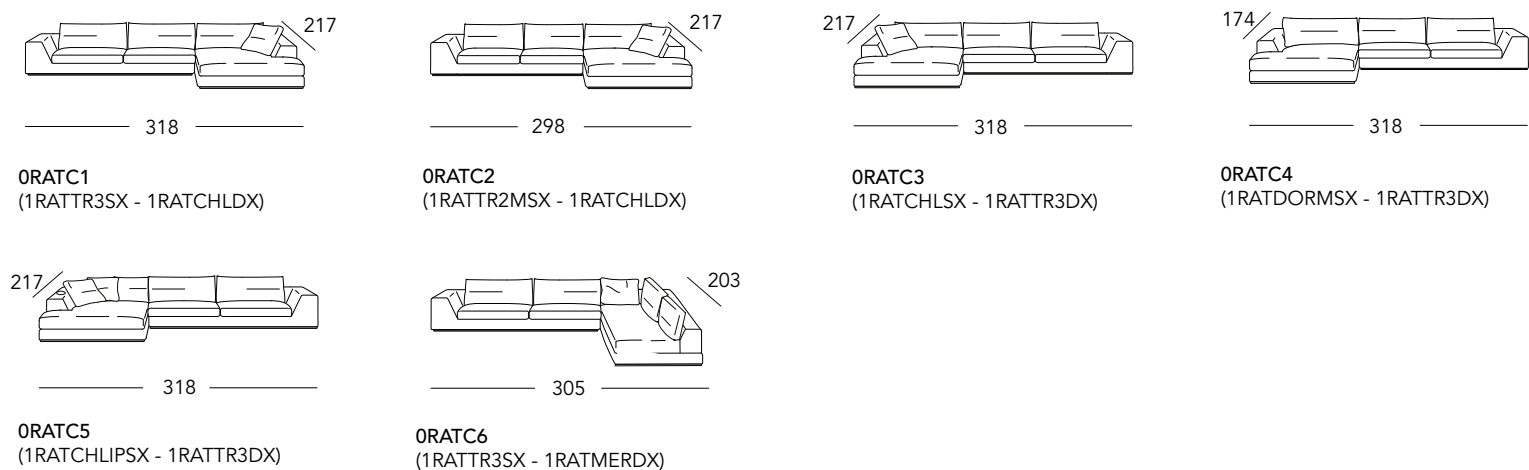

ELEMENTI / ELEMENTS / ELEMENTS / ELEMENTE

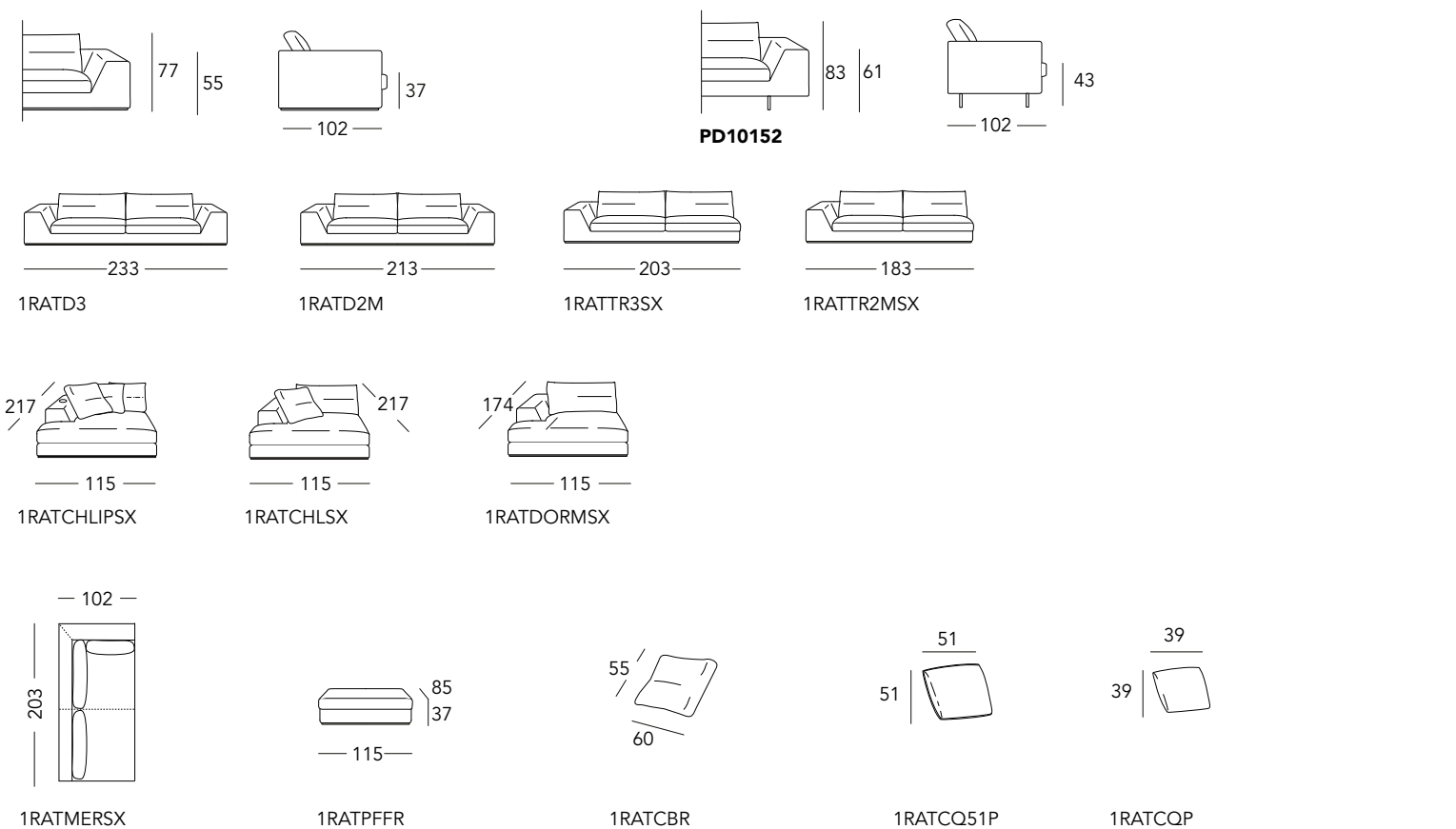

RALPH

Pelle | leather | cuir | Leder



COMPOSIZIONI / COMPOSITIONS / COMPOSITIONS / KOMPOSITIONEN

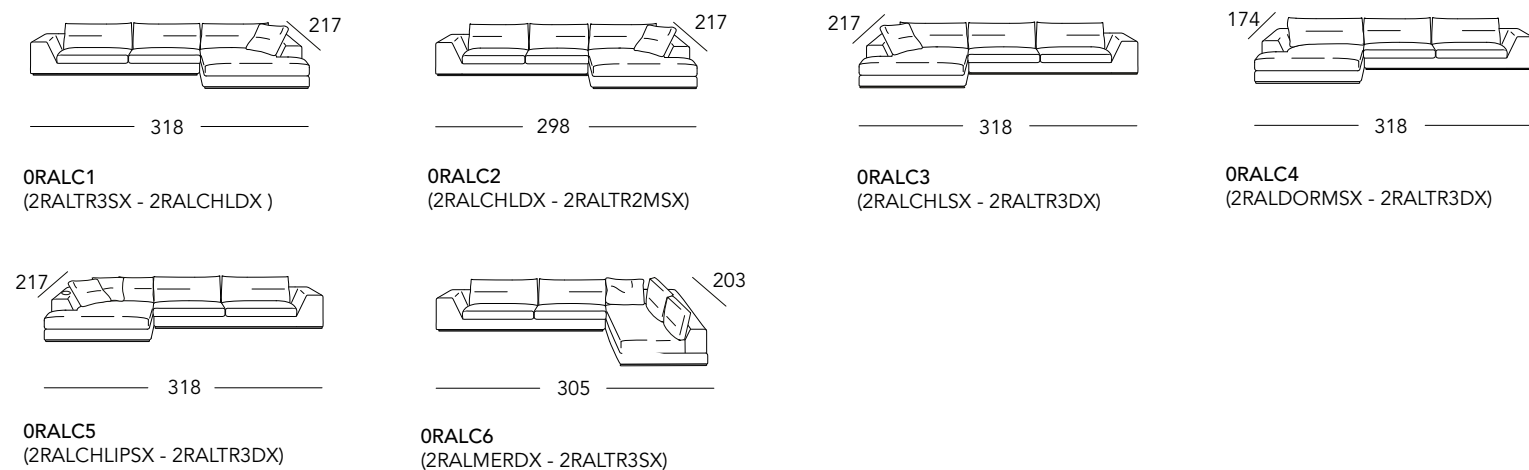

ELEMENTI / ELEMENTS / ELEMENTS / ELEMENTE

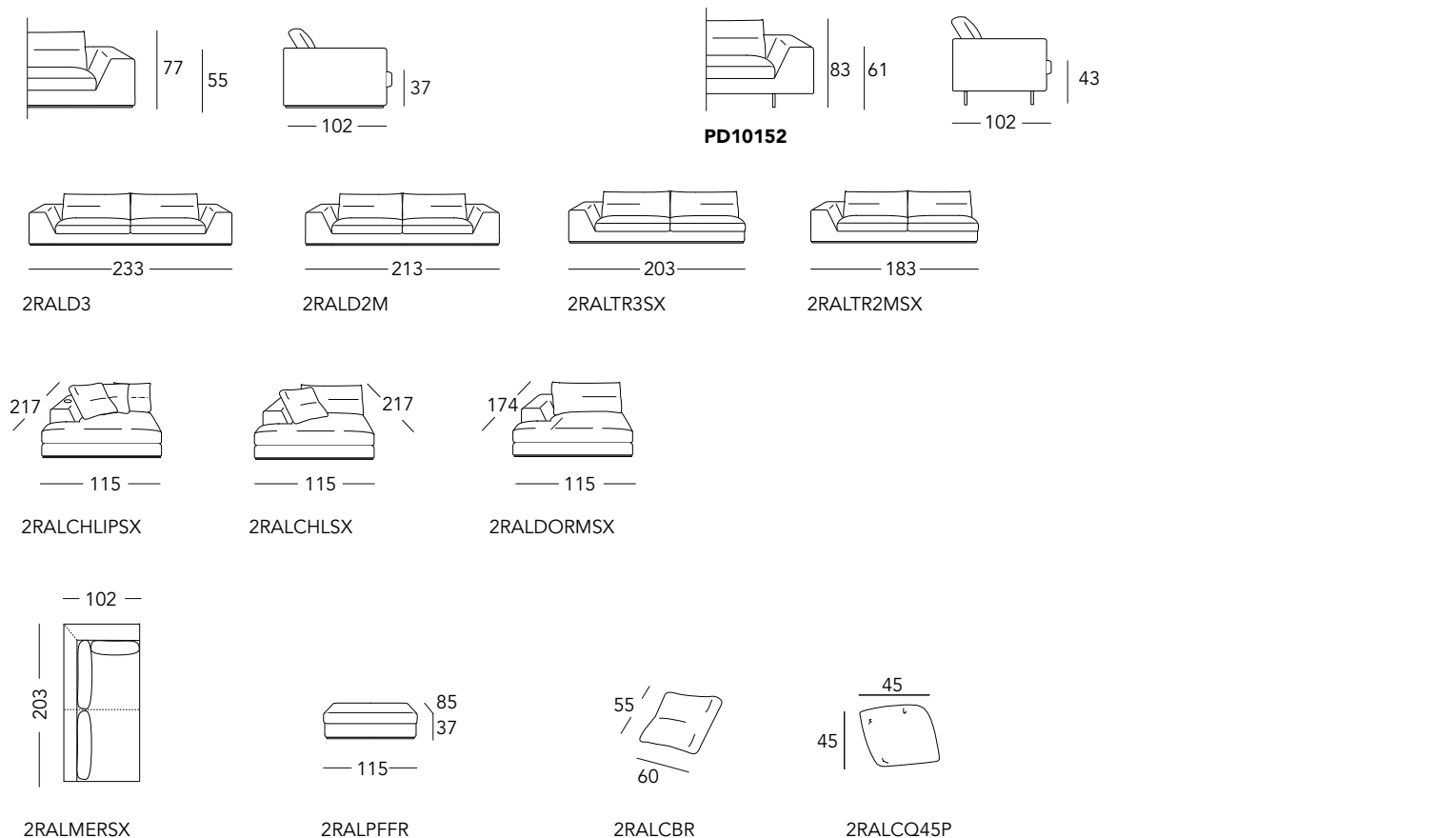

BLOW

Tessuto | fabric | tissu | Stoff



COMPOSIZIONI / COMPOSITIONS / COMPOSITIONS / KOMPOSITIONEN

OBLOC1
(1BLOMERDXB - 1BLOD3SXA)

OBLOC2
(1BLOPT65 - 1BLOD3SXA - 1BLOMERDXB)

OBLOC3
(1BLOPT65 - 1BLOCHLSXB - 1BLOD3DXA)

OBLOC4
(1BLOCHLDA - 1BLOD3SXA)

OBLOC5
(1BLOD2DXB - 1BLOD2SXB - 1BLOAAP)

ELEMENTI / ELEMENTS / ELEMENTS / ELEMENTE

86 | 57 | 102 | 46 | 102 | 46

244 | 244 | 244 | 244 | 211 | 211

1BLOD3MA | 1BLOD3MB | 1BLOD3MSPBSAD | 1BLOD3MSPASBD | 1BLOD3A | 1BLOD3B

211 | 211 | 173 | 173 | 120 | 120 | 101 | 101

1BLOD3SPASBD | 1BLOD3SPBSAD | 1BLOD2A | 1BLOD2B | 1BLOPMA | 1BLOPMB | 1BLOPA | 1BLOPB

230 | 230 | 197 | 197 | 160 | 160

1BLOD3MSXA | 1BLOD3MSXB | 1BLOD3SXA | 1BLOD3SXB | 1BLOD2SXA | 1BLOD2SXB

106 | 106 | 87 | 87 | 130 | 130 | 106 | 106

1BLOPMSXA | 1BLOPMSXB | 1BLOPSXA | 1BLOPSXB | 1BLOMERSXA | 1BLOMERSXB | 1BLOCHLSXA | 1BLOCHLSXB

169 | 130 | 117 | 61 | 109 | 100 | 46 | 50 | 46 | 75 | 65 | 55

1BLOMERSX | 1BLOAAP | 1BLOBG | 1BLOPFF | 1BLOPFFSM | 1BLOPT65 | 1BLOCL

BLOW

Pelle | leather | cuir | Leder



COMPOSIZIONI / COMPOSITIONS / COMPOSITIONS / KOMPOSITIONEN

OBLWC1
(2BLWD3SXA - 2BLWMERDXB)

OBLWC2
(2BLWD3SXA - 2BLWMERDXB - 2BLWPT65)

OBLWC3
(2BLWD3DXA - 2BLWCHLSXB - 2BLWPT65)

OBLWC4
(2BLWCHLDA - 2BLWD3SXA)

OBLWC5
(2BLWD2DXB - 2BLWD2SXB - 2BLWAAAP)

ELEMENTI / ELEMENTS / ELEMENTS / ELEMENTE

86 | 57 | 102 | 46 | 102 | 46

244 | 244 | 244 | 244 | 211 | 211

2BLWD3MA | 2BLWD3MB | 2BLWD3MSPBSAD | 2BLWD3MSPASBD | 2BLWD3A | 2BLWD3B

211 | 211 | 173 | 173 | 120 | 120 | 101 | 101

2BLWD3SPASBD | 2BLWD3SPBSAD | 2BLWD2A | 2BLWD2B | 2BLWPMA | 2BLWPMB | 2BLWPA | 2BLWPB

230 | 230 | 197 | 197 | 160 | 160

2BLWD3MSXA | 2BLWD3MSXB | 2BLWD3SXA | 2BLWD3SXB | 2BLWD2SXA | 2BLWD2SXB

106 | 106 | 87 | 87 | 130 | 130 | 106 | 106

2BLWPMSXA | 2BLWPMSXB | 2BLWPSXA | 2BLWPSXB | 2BLWMERSXA | 2BLWMERSXB | 2BLWCHLSXA | 2BLWCHLSXB

169 | 130 | 117 | 61 | 109 | 100 | 46 | 50 | 46 | 75 | 65 | 55

2BLWMERSX | 2BLWAAAP | 2BLWBG | 2BLWPFF | 2BLWPFFSM | 2BLWPT65 | 2BLWCL

OVERLAND

Tessuto | fabric | tissu | Stoff



COMPOSIZIONI / COMPOSITIONS / COMPOSITIONS / KOMPOSITIONEN

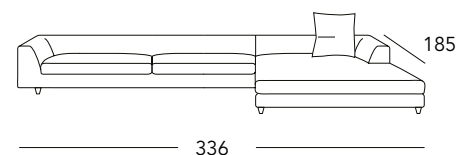

00VEC1
(1OVECHDX - 1OVED3SX)

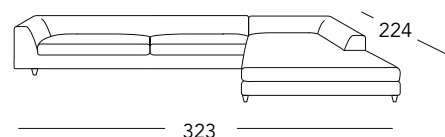

00VEC2
(1OVEMERDX - 1OVED3SX)

ELEMENTI / ELEMENTS / ELEMENTS / ELEMENTE

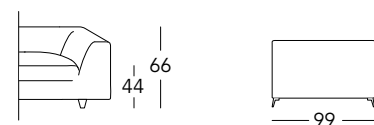

1OVED3

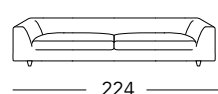

1OVED2M

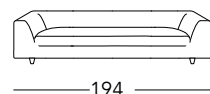

1OVED2

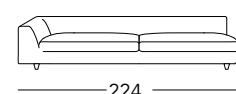

1OVED3SX

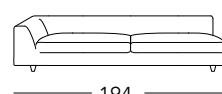

1OVED2MSX

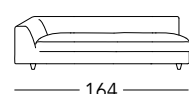

1OVED2SX

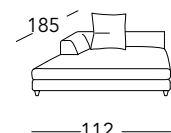

1OVECHLSX

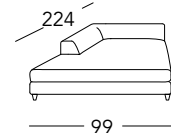

1OVEMERSX

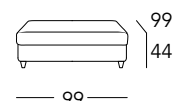

1OVEPFFQ

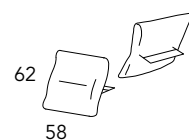

1OVECSS

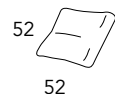

1OVECSH

KALINDA

Tessuto | fabric | tissu | Stoff

CHAISE LONGUE / CHAISE LONGUE / CHAISE LONGUE / LIEGE

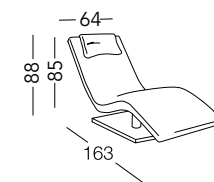

C1KLT
(CHLGKLT - PTKLT)

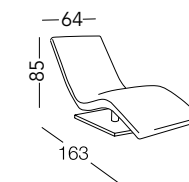

CHLGKLT

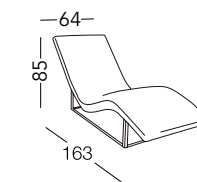

CHLKLT

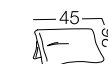

PTKLT



KALINDA

Pelle | leather | cuir | Leder

CHAISE LONGUE / CHAISE LONGUE / CHAISE LONGUE / LIEGE

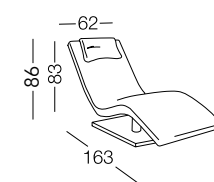

C1PKLD
(CHLGPKLD - PTPKLD)

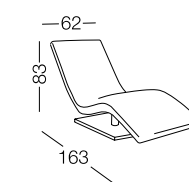

CHLGPKLD

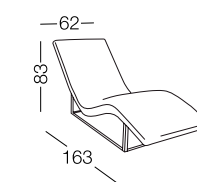

CHLPKLD

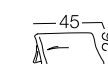

PTPKLD

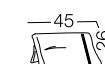

PTSPKLD



WILD

Tessuto | fabric | tissu | Stoff



COMPOSIZIONI / COMPOSITIONS / COMPOSITIONS / KOMPOSITIONEN

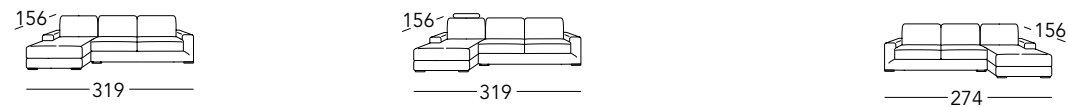

0WITC1
(1WITDORMSX - 1WITD3DX)

0WITC2
(1WITPT75 - 1WITDORMSX - 1WITD3DX)

0WITC3
(1WITD2MSX - 1WITDORSX)

ELEMENTI / ELEMENTS / ELEMENTS / ELEMENTE

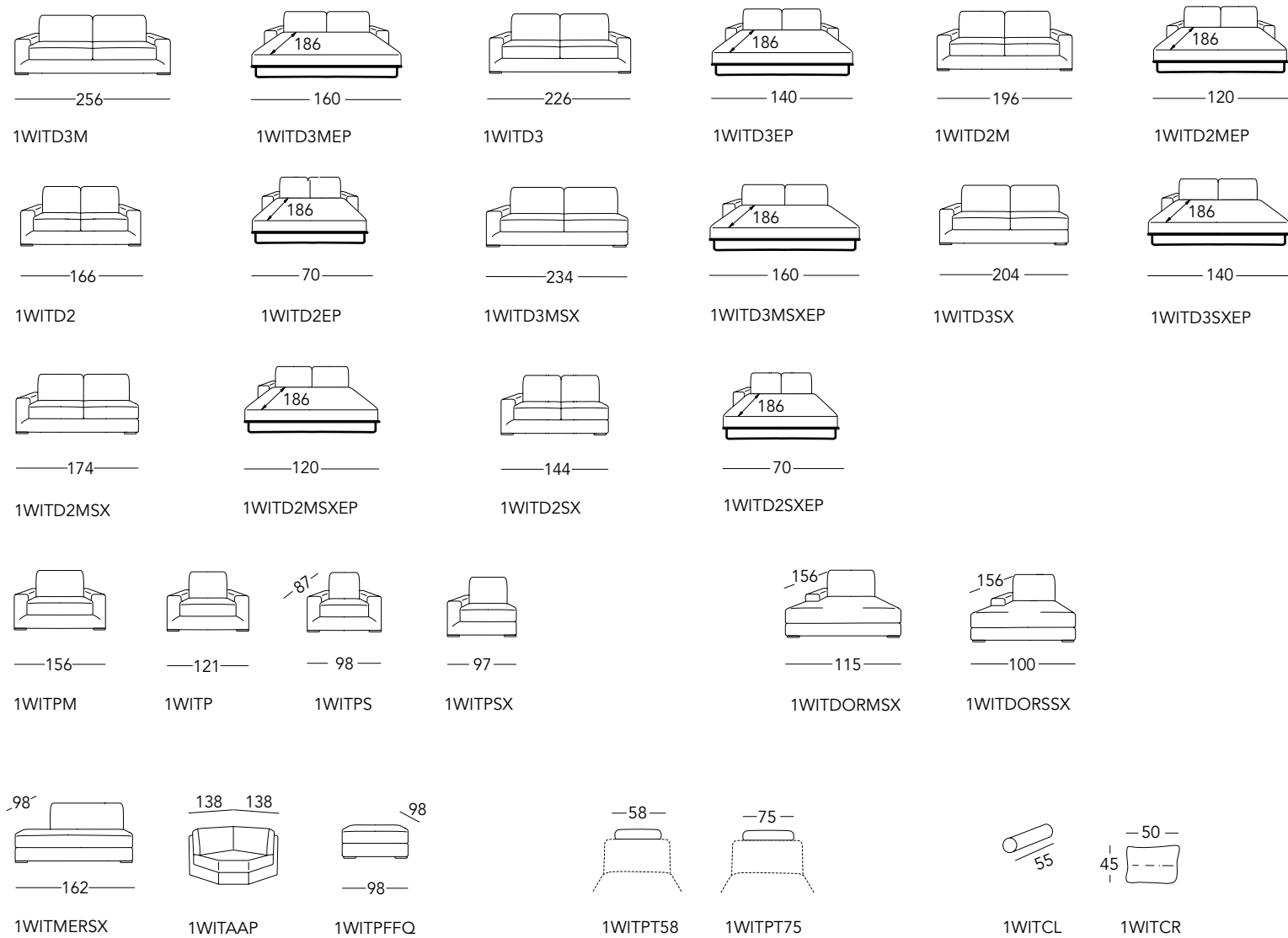
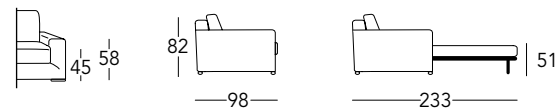

WILD

Pelle | leather | cuir | Leder



COMPOSIZIONI / COMPOSITIONS / COMPOSITIONS / KOMPOSITIONEN

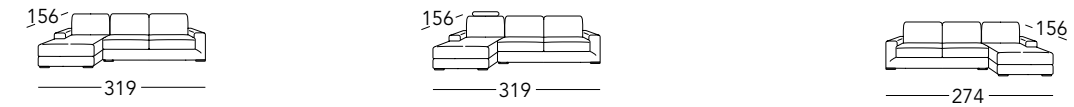

0WILC1
(2WILD3DX - 2WILDORMSX)

0WILC2
(2WILDORMSX - 2WILD3DX - 2WILPT75)

0WILC3
(2WILDORSX - 2WILD2MSX)

ELEMENTI / ELEMENTS / ELEMENTS / ELEMENTE

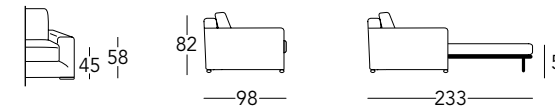

SUMMER

Tessuto | fabric | tissu | Stoff

COMPOSIZIONI / COMPOSITIONS / COMPOSITIONS / KOMPOSITIONEN

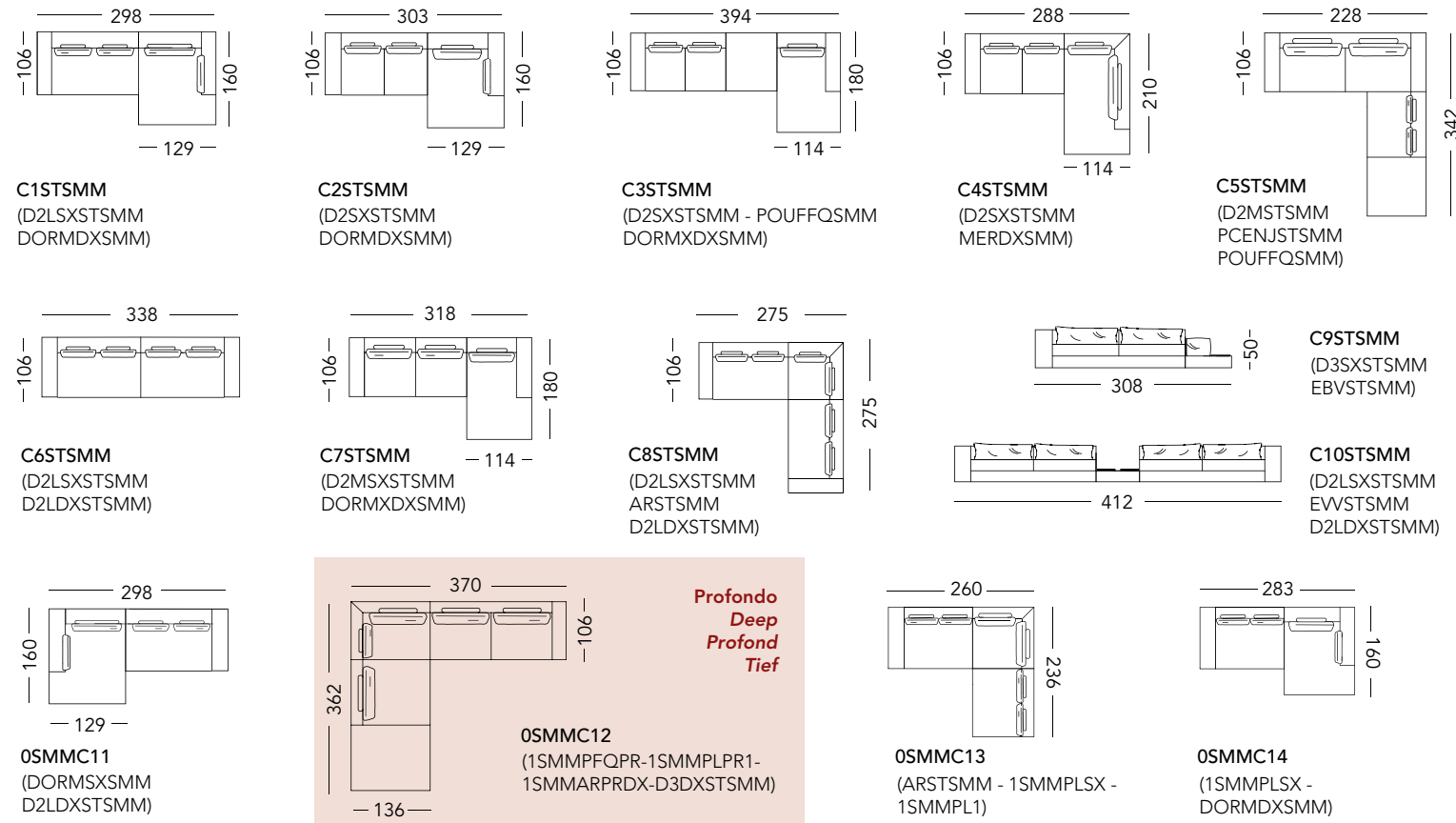

ELEMENTI / ELEMENTS / ELEMENTS / ELEMENTE

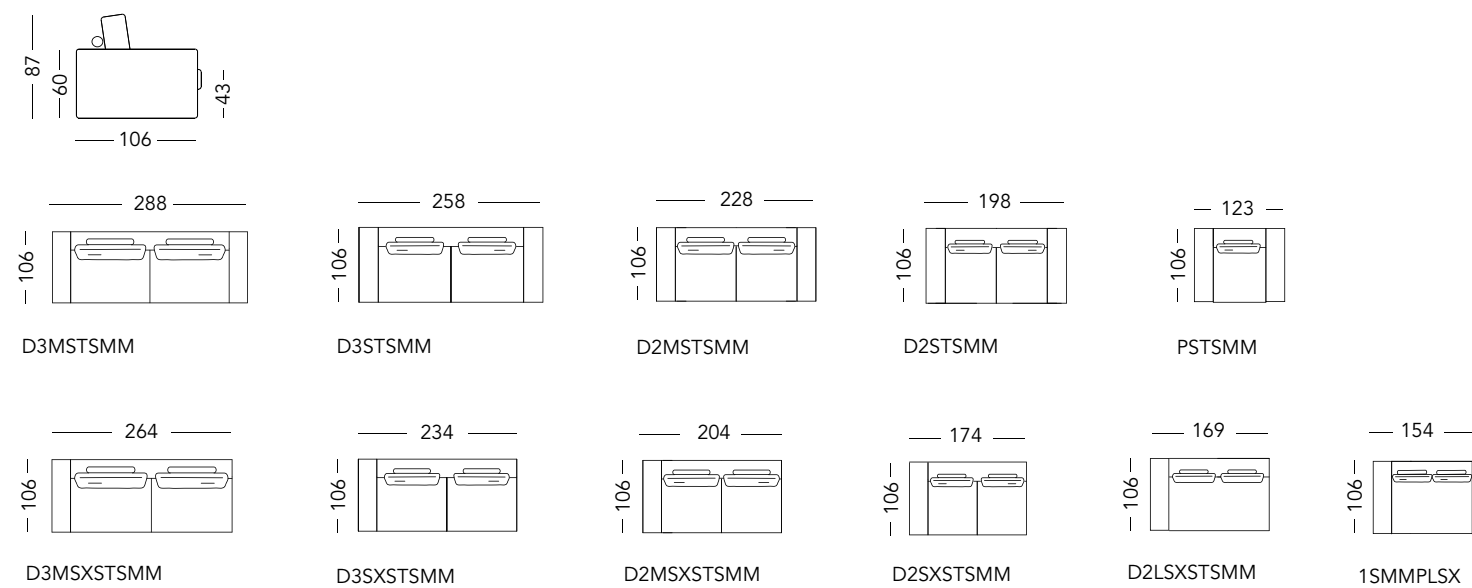

ELEMENTI / ELEMENTS / ELEMENTS / ELEMENTE

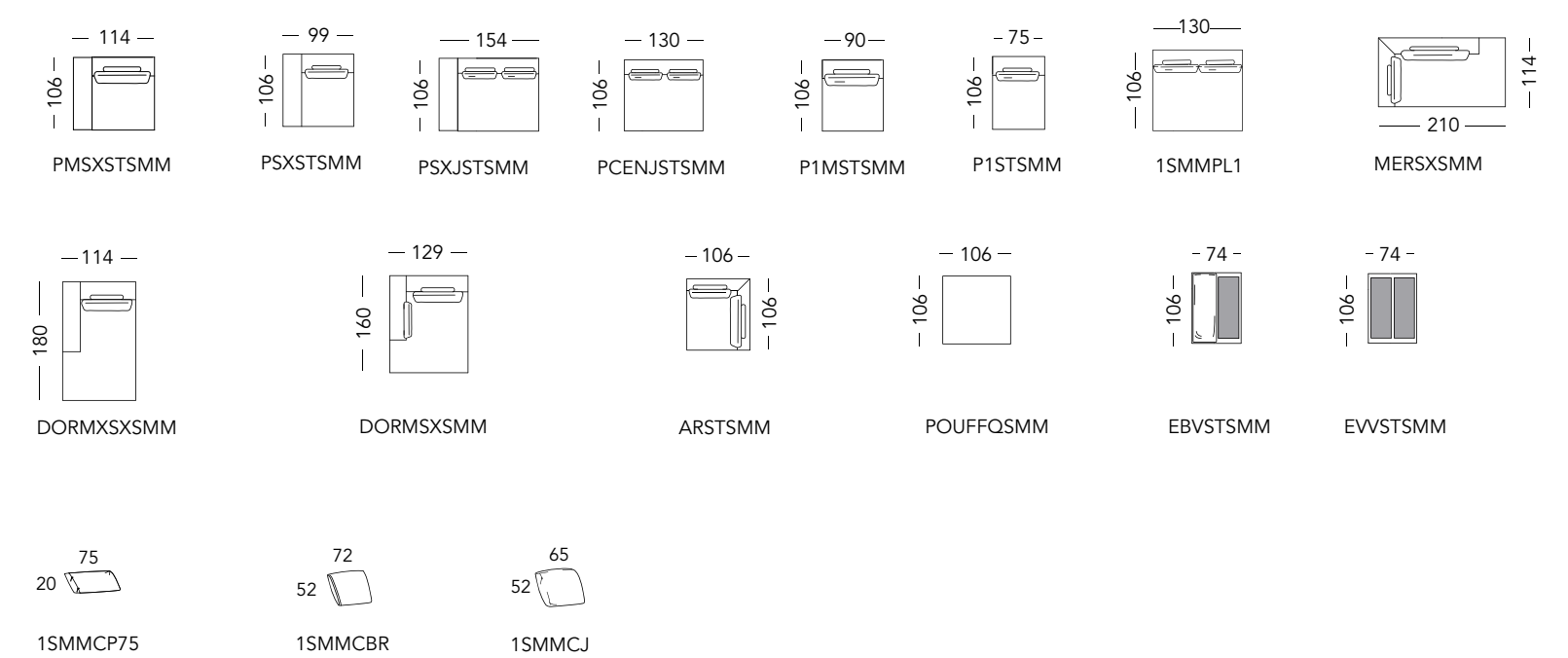

ELEMENTI / ELEMENTS / ELEMENTS / ELEMENTE

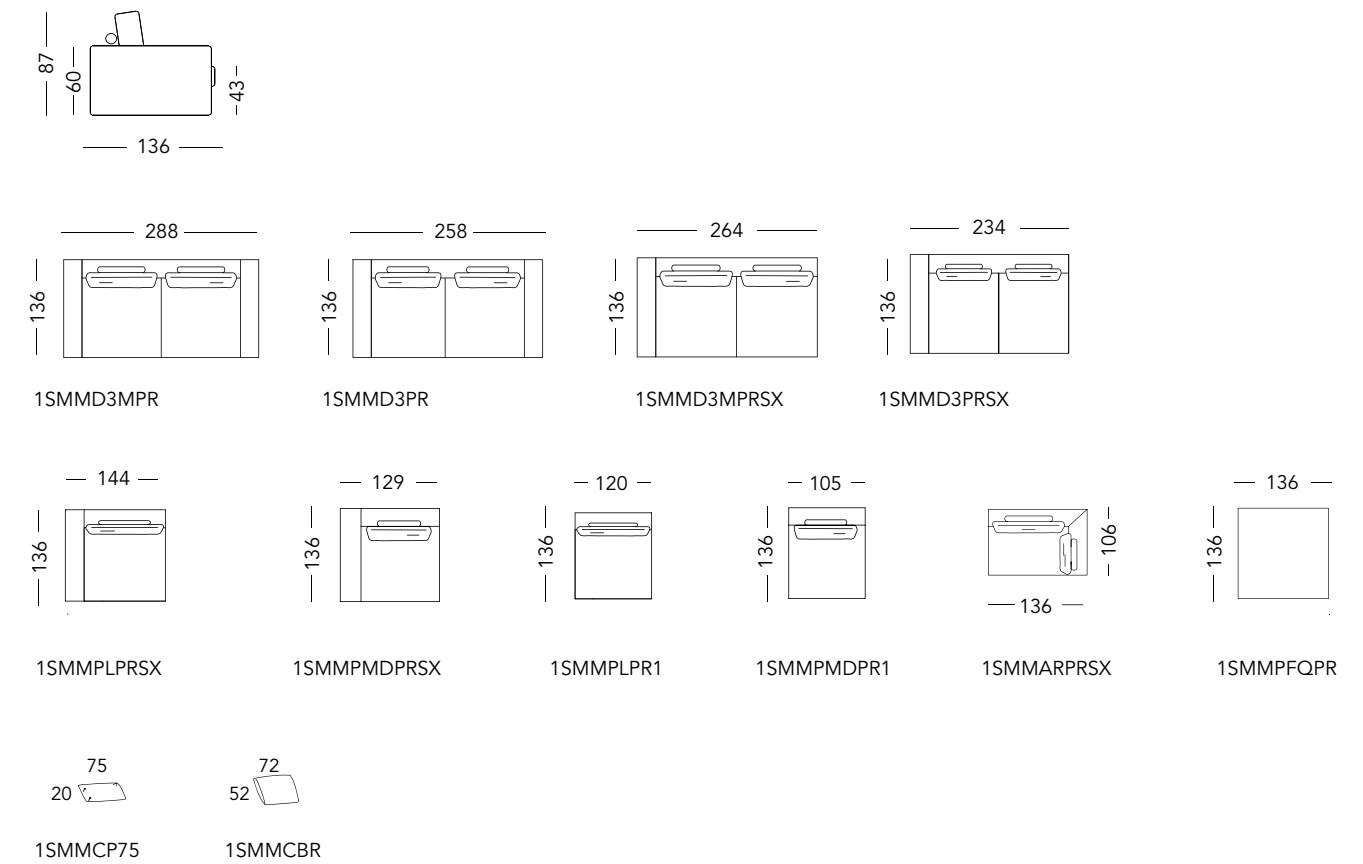

PROFONDO

Deep | Profond | Tief

SUMMER

Pelle | leather | cuir | Leder



COMPOSIZIONI / COMPOSITIONS / COMPOSITIONS / KOMPOSITIONEN

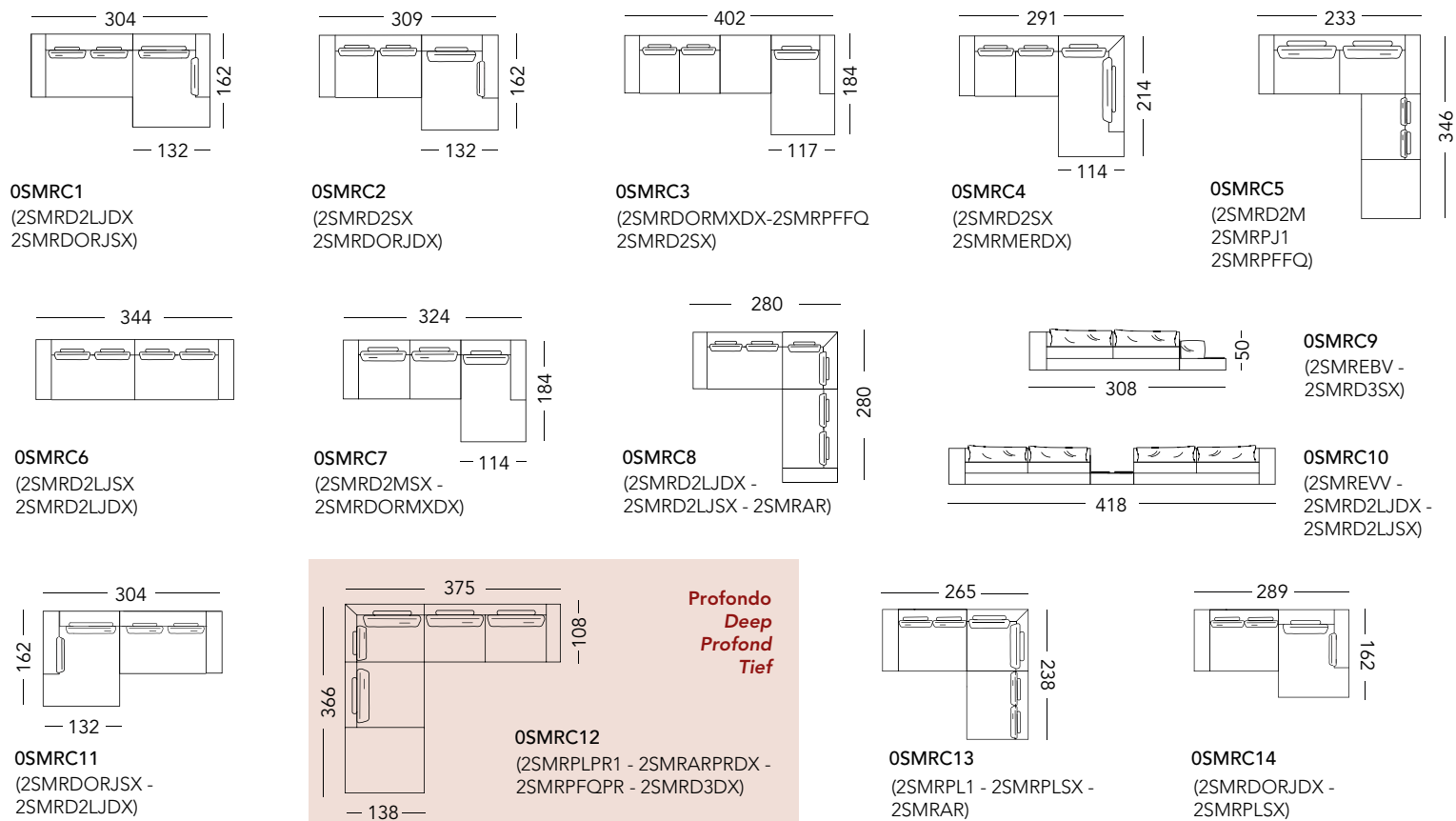

ELEMENTI / ELEMENTS / ELEMENTS / ELEMENTE

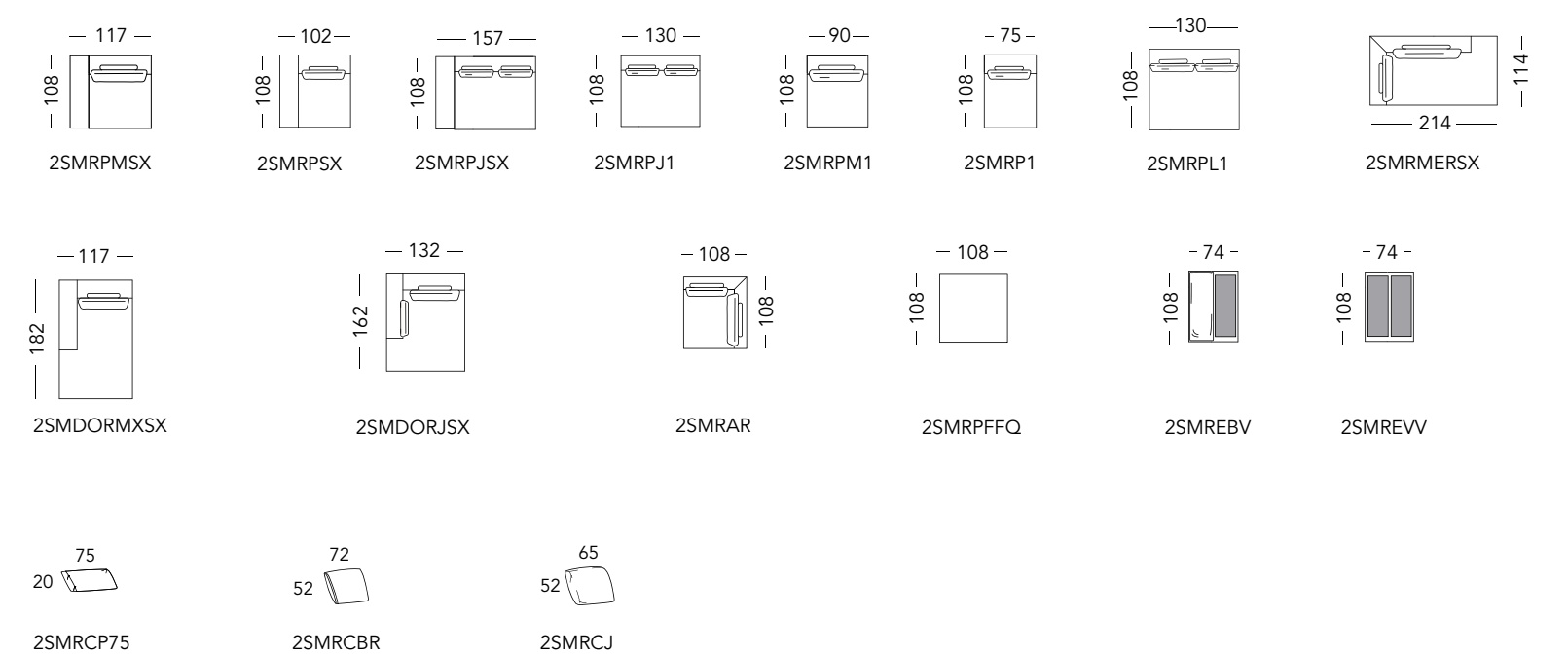

ELEMENTI / ELEMENTS / ELEMENTS / ELEMENTE

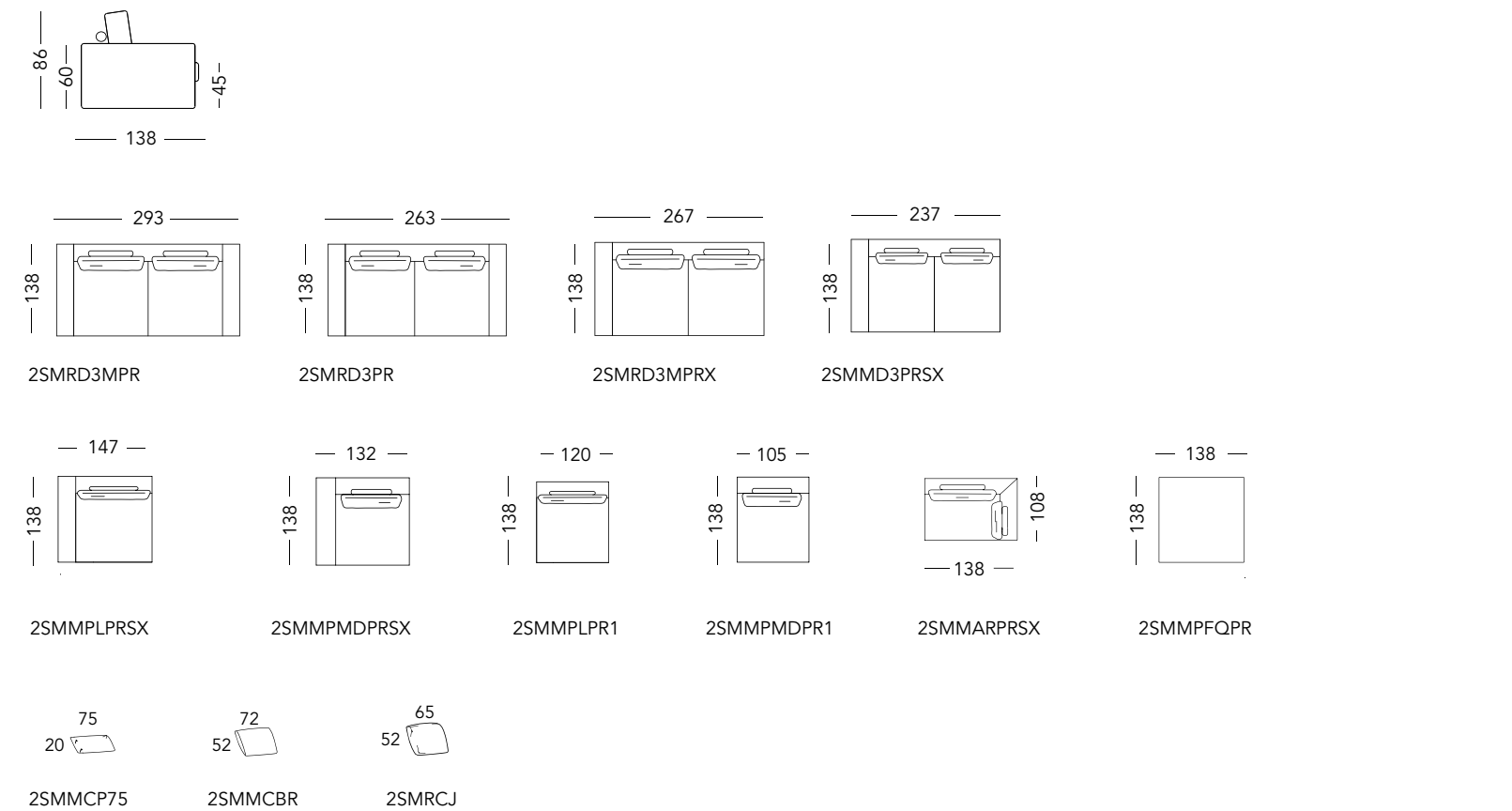

PROFONDO

Deep | Profond | Tief

ELEMENTI / ELEMENTS / ELEMENTS / ELEMENTE

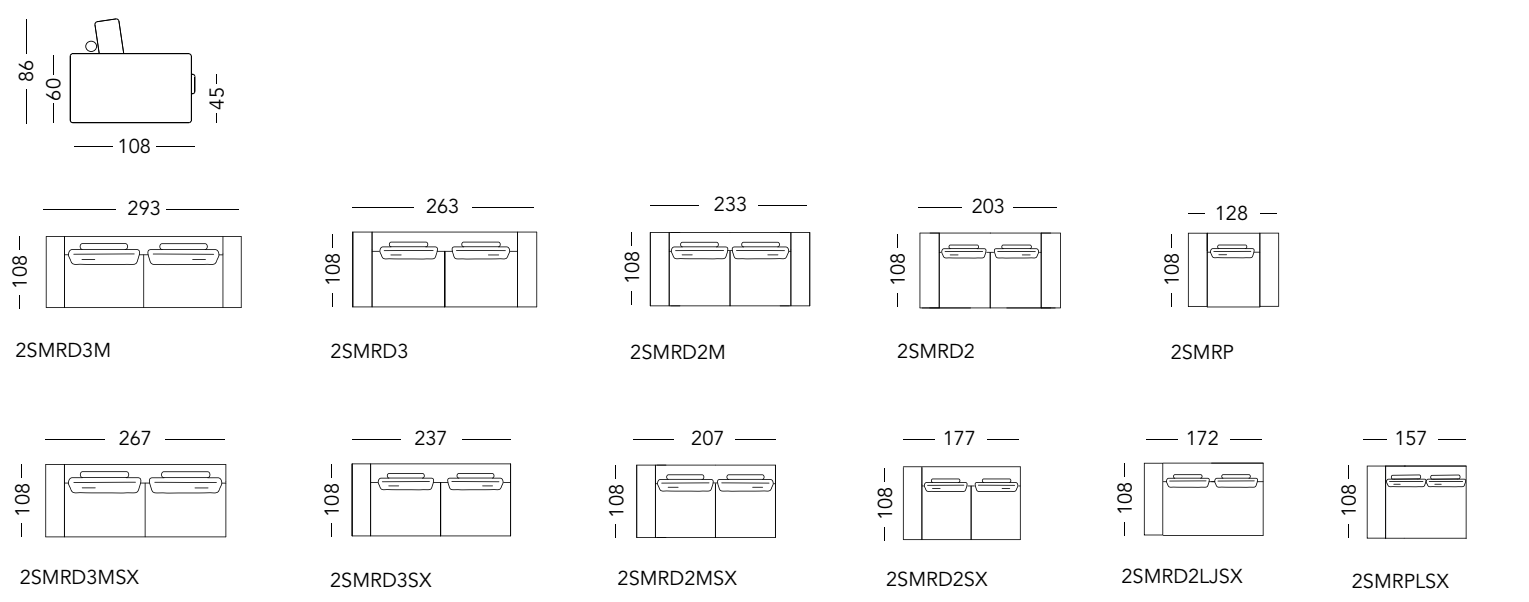



descrizioni tecniche

technical descriptions

alberta

MANHATTAN

Struttura portante in massello di legno. Cuscino di schienale in **mollapiuma** rivestito con fodera di cotone (oppure in poliuretano espanso), cuscino di seduta in poliuretano espanso. Piedino realizzato in metallo cromato oppure in legno finitura moka.

*Main structure in solid wood. Seat cushion in polyurethane foam, backrest cushion in **down polyester** covered with cotton lining (or in polyurethane foam). Chromium plated metal feet or wooden feet moca finishing.*

*Carcasse principal en bois massif. Assise en polyuréthane expansé, dossier en **mollapiuma** sous housse de coton (ou en polyuréthane expansé). Pied en métal chrome ou en bois finition moka.*

*Tragstruktur aus Massivholz (Schichtholz). Sitzkissen aus Polyurethanschaum, Rückenkissen aus **Daunengemisch** im Baumwoll-Inlett (oder aus Polyurethanschaum). Füße aus Metall verchromt oder Holz mokkafarbig.*



Cod. 158

Cod. 241

BROADWAY

Struttura portante in massello di legno. Cuscino di schienale in **mollapiuma** rivestito con fodera di cotone (oppure in poliuretano espanso), cuscino di seduta in poliuretano espanso. Piedino realizzato in metallo cromato oppure in legno finitura moka.

*Main structure in solid wood. Seat cushion in polyurethane foam, backrest cushion in **down polyester** covered with cotton lining (or in polyurethane foam). Chromium plated metal feet or wooden feet moca finishing.*

*Carcasse principal en bois massif. Assise en polyuréthane expansé, dossier en **mollapiuma** sous housse de coton (ou en polyuréthane expansé). Pied en métal chrome ou en bois finition moka.*

*Tragstruktur aus Massivholz (Schichtholz). Sitzkissen aus Polyurethanschaum, Rückenkissen aus **Daunengemisch** im Baumwoll-Inlett (oder aus Polyurethanschaum). Füße aus Metall verchromt oder Holz mokkafarbig.*



Cod. 159

Cod. 265

RALPH

Struttura portante in massello di legno. Cuscino di seduta in poliuretano espanso, cuscino di schienale in **piuma d'oca** e particelle di poliuretano espanso. Basamento cromato oppure piedino in metallo cromato.

*Main structure in solid wood. Seat cushion in polyurethane foam, backrest cushion in **goose feathers** and polyurethane chips. Chromium plated metal base or feet.*

*Carcasse principal en bois massif. Assise en polyuréthane expansé, dossier en **plumes d'oie** et particules de polyuréthane expansé. Piétement en métal chrome ou pieds en métal chrome.*

*Tragstruktur aus Massivholz (Schichtholz). Sitzkissen aus Polyurethanschaum, Rückenkissen aus **Gänsedaunen** und Polyurethanschaum-Teilchen. Verchromte Metall Basis oder Füße.*



Cod. PD10152

Base



Cod. PD10152



Cod. PD10154

BLOW

Struttura portante in massello di legno. Cuscino di seduta in **piuma d'oca** e fibra di poliestere con inserto in poliuretano espanso, cuscino di schienale in **piuma d'oca** e fibra di poliestere. Due opzioni piedino entrambe in metallo cromato.

*Main structure in solid wood. Seat cushion in polyurethane foam with upper part in **goose feathers** and polyester fibre, backrest cushion in **goose feathers** and polyester fibre. Two feet options both in chromium plated metal.*

*Carcasse principal en bois massif. Assise en polyuréthane expansé avec partie supérieur en **plumes d'oie** et fibre de polyester, dossier en **plumes d'oie** et fibre de polyester. Pieds disponibles en deux versions en métal chromé .*

*Tragstruktur aus Massivholz (Schichtholz). Sitzkissen aus Polyurethanschaum Oberteil aus **Gänsedaunen** und Polyesterfaser, Rückenkissen aus **Gänsedaunen** und Polyesterfaser. Zwei Füße Optionen beiden aus Metall verchromt.*



Cod. PD10155



Cod. PD10152

OVERLAND

Struttura portante in massello di legno. Cuscino di seduta in poliuretano espanso, cuscino di schienale in **piuma d'oca** e fibra di poliestere. Due opzioni piedino entrambe in metallo cromato.

*Main structure in solid wood. Seat cushion in polyurethane foam, backrest cushion in **goose feathers** and polyester fibre. Two feet options both in chromium plated metal.*

*Carcasse principal en bois massif. Assise en polyuréthane expansé, dossier en **plumes d'oie** et fibre de polyester. Pieds disponibles en deux versions en métal chromé .*

*Tragstruktur aus Massivholz (Schichtholz). Sitzkissen aus Polyurethanschaum, Rückenkissen aus **Gänsedaunen** und Polyesterfaser. Zwei Füße Optionen beiden aus Metall verchromt.*



Cod. PD10145



Cod. PD10146

WILD

Struttura portante in massello di legno. Cuscino di seduta in **piuma d'oca** e fibra di poliestere con inserto in poliuretano espanso, cuscino di schienale in **piuma d'oca** e fibra di poliestere. Piedino in metallo cromato oppure in legno finitura moka.

*Main structure in solid wood. Seat cushion in polyurethane foam with upper part in **goose feathers** and polyester fibre, backrest cushion in **goose feathers** and polyester fibre. Chromium plated metal feet or wooden feet moca finishing.*

*Carcasse principal en bois massif. Assise en polyuréthane expansé avec partie supérieur en **plumes d'oie** et fibre de polyester, dossier en **plumes d'oie** et fibre de polyester. Pieds en métal chrome ou en bois finition moca.*

*Tragstruktur aus Massivholz (Schichtholz). Sitzkissen aus Polyurethanschaum Oberteil aus **Gänsedaunen** und Polyesterfaser, Rückenkissen aus **Gänsedaunen** und Polyesterfaser. Füße aus Metall verchromt oder aus Holz mokkafarbig.*

SUMMER

Struttura portante in massello di legno. Molleggio realizzato con molle di tipo **Nosag**. Cuscino di schienale in **piuma d'oca** e fibra di poliestere con inserto in poliuretano espanso rivestito con fodera di cotone, cuscino di seduta in **piuma d'oca** e fibra di poliestere con inserto in poliuretano espanso rivestito con fodera di cotone.

*Main structure in solid wood. Springing system through **Nosag** springs. Backrest cushion polyurethane foam with upper part in **goose feathers** and polyester fibre covered with cotton covers, seat cushion in polyurethane foam with upper part **goose feathers** and polyester fibre covered with cotton covers.*

*Carcasse principal en bois massif. Suspensions réalisé avec ressort **Nosag**. Coussin de dossier en polyuréthane expansé avec partie supérieur en **plumes d'oie** et fibre de polyester sous housse de coton, coussin d'assise en polyuréthane expansé et **plumes d'oie** et fibre de polyester et sous housse de coton.*

*Tragstruktur aus Massivholz. Federung bestehend aus **Nosag** Riemen. Rückenkissen aus Polyurethanschaum Oberteil aus **Gänsedaunen** und Polyesterfaser, Abgedeckt mit Baumwolle; Sitzkissen Polyurethanschaum Oberteil aus **Gänsedaunen** und Polyesterfaser, Abgedeckt mit Baumwolle.*



KALINDA

Struttura portante in massello di legno. Imbottitura in poliuretano espanso e **memory foam**, poggiatesta in **piuma d'oca** e fibra di poliestere. Basamento cromato girevole oppure fisso.

*Main structure in solid wood. Padding in polyurethane foam and **memory foam**, headrest in **goose feathers** and polyester fibre. Chromium plated base swivel or fix.*

*Carcasse principal en bois massif. Rembourrage en polyuréthane expansé et **memory foam**, appuie-tête en **plumes d'oie** et fibre de polyester. Piétement en métal chrome fixe ou tournante.*

*Tragstruktur aus Massivholz (Schichtholz). Polsterung aus Polyurethanschaum und **Memory Foam**, Kopflehne aus **Gänsedaunen** und Polyesterfaser. Metall verchromt Basis drehbar oder fest.*



COMPANY PROFILE

Il marchio ALBERTA da trent'anni rappresenta garanzia di qualità nella progettazione e nella produzione di divani e poltrone. L'azienda opera nel trevigiano, nord-est Italia, dal cui sostrato culturale ha attinto sia la tradizione artigiana sia l'attitudine alla creatività ed al design. Nel corso della sua storia ha sviluppato nei diversi stabilimenti linee di imbottiti sempre rispondenti all'evoluzione del gusto nelle due divisioni base che raggruppano le collezioni in tessuto e quelle in pelle. L'esperienza nell'impiego di entrambi i materiali consente ad Alberta di essere altamente propositiva. L'obiettivo dell'azienda è offrire soluzioni originali di ottimo livello estetico, pratico e qualitativo nel rispetto dei principi dell'etica ambientale.

For thirty years the ALBERTA brand has been recognised as a guarantee of quality in the design and production of sofas and armchairs. The company is headquartered in the Province of Treviso in the north east of Italy and has taken both its tradition of fine craftwork and its passion for creativity and design from this stimulating and active land. In order to meet the needs of ever-changing tastes the company has developed and now manufactures an extensive range of products based on two basic divisions, their textile and leather furniture collections. The experience they have gained working with these materials enables Alberta to be proactive and continually develop new solutions. The company mission is to create original products which combine great looks with practicality and quality while ensuring the utmost respect for the environment.

Le marque ALBERTA depuis 30 ans c'est une garantie de qualité dans la projection et fabrication de fauteuils et canapés. L'usine opère dans la province de Treviso, nord-est de l'Italie, et du substrat culturel de cette zone elle a pris soit la tradition artisanale soit la disposition à la créativité et au design. Au cours de l'histoire elle a développé dans les différents usines des lignes des canapés toujours correspondant à l'évolution du goût dans les deux collections en cuir et tissu. L'expérience dans l'utilisations des matériaux a permis à Alberta d'être bien propositive avec ces collections. L'objectif de l'usine est offrir solutions originales de niveau esthétique, pratique et qualitatif excellent dans le respect des principes de l'éthique de l'ambiance.

Die Marke ALBERTA steht seit dreißig Jahren als Garantie für Qualität in der Entwicklung und Herstellung von Sofas und Sesseln. Das Unternehmen hat seinen Hauptsitz in der Provinz Treviso, im Nordosten Italiens. Angeregt von dieser Kultur und Landschaft schöpft Alberta sowohl aus der handwerklichen Tradition als auch aus der Begabung und Leidenschaft für Kreativität und Design. Im Laufe seiner Geschichte hat das Unternehmen in seinen verschiedenen Betrieben eine breite Palette von Polstermöbel entwickelt, die den Bedürfnissen der Kunden entgegenkommt. Dabei sind zwei grundlegende Richtungen entstanden: die Stoff- und die Lederkollektion. Die gewonnenen Erfahrungen in der Verwendung mit beiden Materialien ermöglicht Alberta sehr aktiv zu sein und ständig neue Lösungen zu entwickeln. Das Unternehmen hat sich zum Ziel gesetzt, originelle Lösungen mit hohen ästhetischen, praktischen und qualitativen Niveau anzubieten und gleichzeitig umweltfreundlich zu sein.

La riproduzione totale o parziale è permessa esclusivamente su nostra autorizzazione.

Le immagini e i disegni contenuti nel presente catalogo sono puramente rappresentativi di questo prodotto e possono subire variazioni e modifiche anche senza preavviso.

Pertanto nella scelta degli articoli per la compilazione dell'ordine, fa fede solamente quanto contenuto nel listino in vigore.

Reproduction, total or partial, is allowed exclusively under licence from our company. The photographs and drawings in this catalogue are only a representation of products and may be varied and changed without notice. When choosing article for your orders, only the details contained in the price-list in force should be considered.

La reproduction totale ou partielle est soumise exclusivement à notre autorisation. Les images et les dessins présents dans ce catalogue sont uniquement des représentations de ce produit et peuvent subir des variations et des modifications même sans préavis. Par conséquent, une fois les articles choisis, lorsque vous remplirez le bon de commande, référez-vous au tarif en vigueur car il est le seul à faire foi.

Die Teilweise oder Gesamte Wiedergabe ist Ausschließlich mit unserer Erlaubnis gestattet. Hinweis: Alle in diesem Katalog enthaltenen Abbildungen sind unverbindlich; wir behalten uns das Recht vor, Änderungen oder Verbesserungen ohne Ankündigung durchzuführen. Maßgeblich für die Auswahl der einzelnen zu bestellenden Produkte ist ausschließlich die jeweils gültige Verkaufspreisliste.

Photo: Fotorama
Renai&Renai

Design: Caseley Giovara

Art direction: Ufficio Stile Alberta Pacific Furniture

Printed in Italy by: Grafiche Antiga 03_2013

alberta[®]
The first name in Italian sofas

Alberta Pacific Furniture S.p.A.
Via Toniolo, 41
31028 Vazzola (TV) Italy
Tel. +39 0438 440440
Fax +39 0438 441555
email: contact@albertasalotti.it

www.alberta.it

alberta[®]
The first name in Italian sofas

MANHATTAN	06
BROADWAY	26
RALPH	38
BLOW	50
OVERLAND	70
WILD	78
SUMMER	94
KALINDA	112